

Proceedings of the secretary State Transport Authority, Thiruvananthapuram

(Present Sri: Alex Paul)

Sub: - Motor vehicles department-Approval of Drg no PB 24.TFB.1 Three Axles, Six wheeler(12 Wheeled) banjo type, sprung chassis drawn semi trailer with Flat Top Platform type- permission granted Reg

Ref-.1.Application received from m/s Laxmi Engineering Workshop, plot no 287/5, National Highway, Mithi rohar, Near Ambika Petrol Pump,Gandhidham, Kutch

2. Proceedings of the Joint Director of Transport Gujrat,Gandhinagar  
Vide Permit no /LMT/L.E.W/463/2011/On/6658 dated 28/09/2011

Order No D1/19983/STA/2011 Dated 18/10/2011

The applicant has requested to grant approval of design of Three Axles, Six wheeler(12 Wheeled) banjo type, sprung chassis drawn semi trailer with Flat Top Platform type. The design is already approved by Joint Director of Transport Gujarat, Gandhinagar vide reference 2<sup>nd</sup> cited above. Hence I Secretary, State Transport Authority, Kerala hereby extend the approval in Kerala State also by exercising the powers delegated to me under sub rule (9) of Rule 305 of KMV rules 1989 and hereby direct all registering authorities in Kerala State to register Semi Trailer with this design as and when produced as a new model subject to the provision of chapter VII of MV Act 1988. The detailed Specification and drawing are attached herewith

Sd/-  
Secretary  
StateTransportAuthority  
Thiruvananthapuram

To  
All Registering Authority,  
Copy to the Applicant  
Approved for issue

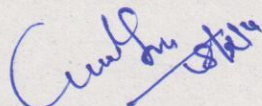
  
Senior Superintendent

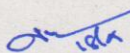

## A P P R O V A L O R D E R

**SUBJECT:** Approval of locally manufactured semi trailer design.  
Manufactured by M/s.Laxmi Engg. Works.  
Design No.463/2011.

- READ:** 1. Application submitted by M/s.Laxmi Engg. Works. Gandhidham. For approval of three axles, six wheeler, (12 wheeled) banjo type, sprung chassis, truck horse drawn semi trailer with flat top platform type. **Drg.No.PB.24.T.FB.1.**
2. Birla Vishvakarma Mahavidyalaya, Vallabh Vidyanagar, has issued scrutiny report vide letter No. F/BVM/M/10/TD/268/1472 dated 27.9.2011 along with design and specification-calculation with specific remarks.

**OBSERVATION:** B.V.Mahavidyalaya has examined the semi trailer design as required by the provisions of Rule 166 of the G.M.V. Rules 1989 and has recommended maximum weights to be assigned as follows:

TYPE OF TRAILER.	PLATFORM SIZE. LOADING AREA.	TYRE SIZE.	MAX.SAFE AXLE WEIGHTS.	MAX.SAFE GROSS LADEN WEIGHTS.
Truck horse drawn Three axles Six wheeler (12 wheeled) Banjo type, Sprung chassis, Flat top type platform. Semi trailer.	Length 7320 mm. Width 2600 mm.	12 Nos. 11.00 x 20, 16 ply.	Rear Axle Weight 24000 kg.  King Pin Reaction 10200 kg.	34200 kg.
<b>Overall dimensions:-</b>	Length 7475 mm.	Width 2600 mm.	Height 1550±25 mm.	

The design complies with the provisions of chapter VII of the Motor Vehicles Act 1988 and rule made there under:

Brake provided: Parking brakes provided as per rule No.97 of the C.M.V. Rules 1989.

As per Para 1 of the Govt.of India's Notification No.SO 728 (E) dated 18/10/1996 and Rule 95 of C.M.V. Rules 1989, the maximum safe axle and gross laden weights will be as follows:

	Certified by B.V.M.	Permissible as per Rule 95 of CMVR 1989.	Permissible as per schedule annexed to GOI's Noti.No. SO 728(E) dated 18/10/1996.
<b>King pin Reaction...</b> (On rear single axle of truck horse fitted with tyre 4 Nos. 11.00 x 20, 16 Ply.)	10200 kg.	13300 kg.	10200 kg.
<b>Rear Axle Weight...</b> (Three axles fitted with tyre 12 Nos. 11.00 x 20, 16 Ply.)	24000 kg.	39900 kg.	24000 kg.
<b>Gross Laden Weight...</b>	34200 kg.	53200 kg.	34200 kg.

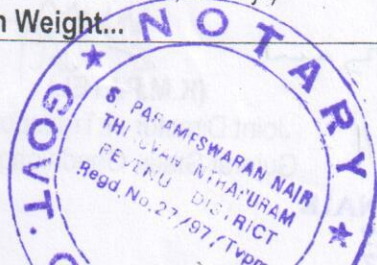

**S. PARAMESWARAN NAIR**

Contd.pto...

# LAXMI ENGINEERING WORKSHOP

## TRAILOR BODY REPAIRS WORKS

PLOT NO 287/5, NATIONAL HIGHWAY, MITHI ROHAR, NEAR AMBIKA PETROL PUMP, GANDHIDHAM-KUTCH

REF NO: 23/2011-12

DATE: 15.10.11

SPECIFICATION - TRUCK HORSE DRAWN SEMI TRAILOR OF THREE AXLES, SIX WHEELER (12 WHEELED) BANJO TYPE, SPRUNG CHASIS, FLAT TOP PLATFORM

REF DRG NO PB -24 . T .FB.1.

### DIMENSIONS :-

OVERALL LENGTH : 7475 mm

OVERALL WIDTH : 2600 mm

OVERALL HEIGHT : 1550+ 25 mm

SL NO	DESCRIPTION	QTY	MATERIAL	REMARKS
1	CHASIS LONG & CROSS BEARER	02/07	ST-52	FAB SECTION
2	FRAME LONG & CROSS BEARER	02/12	ST-52	ISMIC 150
3	LONG/CROSS FOR RU PLATE	02/02	ST-52	5 THK
4	PLATFORM SHEET	01	ST-52	3 THK CHEQUERED
5	SIDE & REAR GUARD	02/01	ST-52	STD
6	TWIST LOCK	04	STD	STD
7	RUBBING PLATE	01	ST-52	10 THK
8	KINGPIN	01	STD	50.8mm AS PER IS6763 PART 1
9	LANDING JACK	02/02	STD	STD
10	BRAKE SYSTEM	1 SET	STD	STD
11	MUDGUARD	04	STD	STD
12	UBET WITH STAND	02	STD	STD
13	TAIL LAMP WITH REFLECTOR	02	STD	STD
14	SPRING	06	55 SiMn90	9 LEAVES OF 90 X16
15	SUSPENSION ASSY	3 SET	STD	STD
16	AXLE	03	ST - 52	150 X 130 X 12 THK
17	WHEEL ASSAY	3 SET	STD	STD
18	TYRES	012	STD	11.00 X 20 - 16 PR OR CAPABLE



Althina Soman  
15-10-2011

**S. PARAMESWARAN NAIR**  
ADVOCATE & NOTARY  
Roll No. K.37 / 1967  
American Institute Building  
Vanchiyoor, Trivandrum, Kerala

SUITABLE PRIME MOVER SHOWN FOR DIMENSIONS ONLY

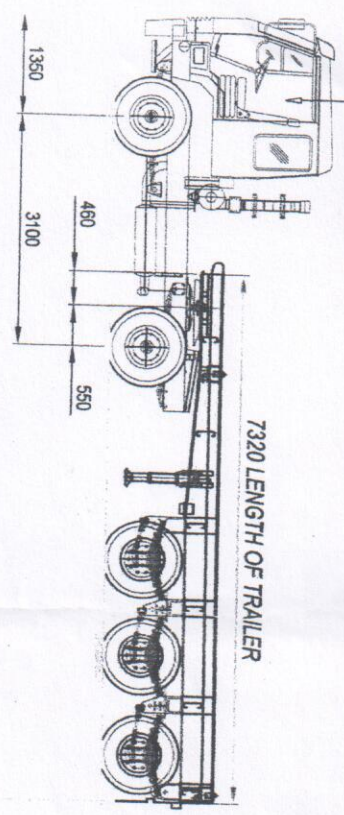

10760 O/A LENGTH OF COMBINATION (NOT TO SCALE)

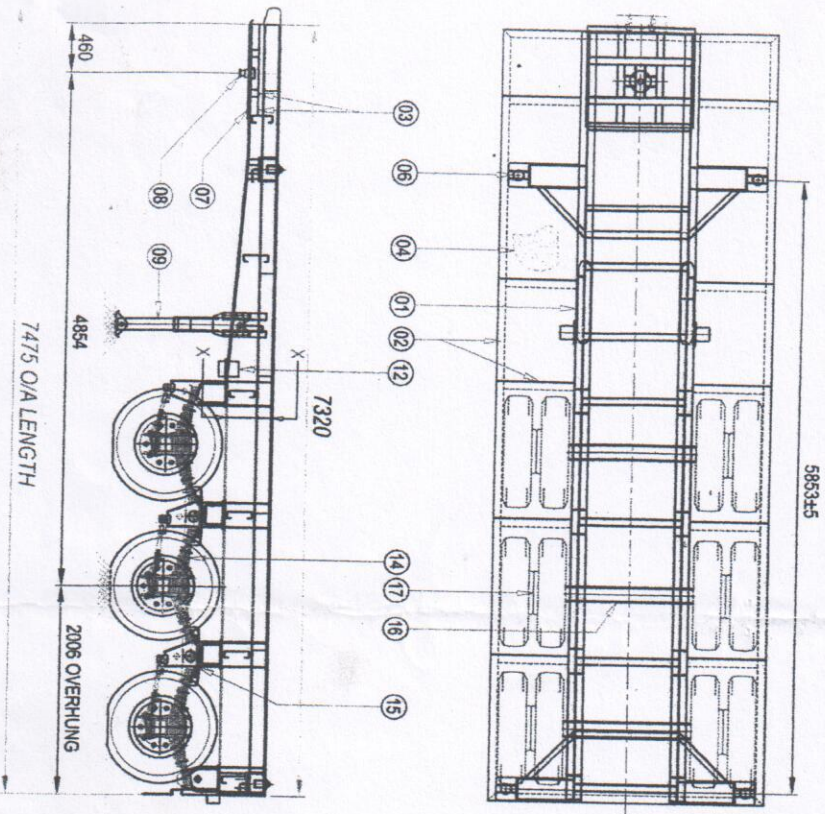

7475 O/A LENGTH

2006 OVERHUNG

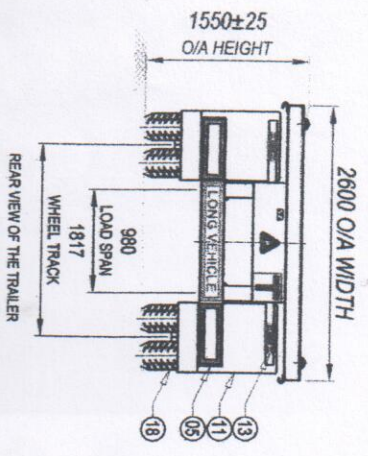

REAR VIEW OF THE TRAILER

SECTION-XX (NOT TO SCALE)

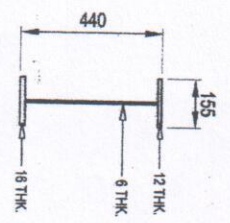

*Attested*  
*Saravud*  
15-10-20

**S. PARAMESWARAN NAIR**  
ADVOCATE & NOTARY  
Roll No. K.37/1967  
American Institute Building  
Vanchiyoor, P.O. Vanchiyoor  
Dist. Kottayam-32

Joint Director of Transport  
Gujarat State, Gandhinagar.

S/N	DESCRIPTION	QTY.	MAT.	REMARKS
18	TYPES	12	STD	11.04.20.16.F-3
17	WHEEL ASSY.	3 SET	STD	
16	AXLE	03	ST-52	150X130X12 T
15	SUSPENSION ASSY.	3 SET	STD	
14	SPRING	06	55 S2 M90	9 LEAVES 3/4"
13	TAIL LAMP WITH REFLECTOR	02	STD	STD
12	LUBET WITH STAND	02	"	"
11	MUDGUARD	04	"	"
10	BRAKE SYSTEM	1 SET	"	"
09	LANDING JACK	2/2	"	"
08	KING PIN	01	"	Ø 50.8 18.6 53 AS
07	RUBBING PLATE	04	ST-52	10 THK
06	TWIST LOCK	01	STD	STD
05	SIDE & REAR GUARD	2/1	ST-52	
04	PLATFORM SHEET	01	"	3 THK CHCQ
03	LONG/CROSS FOR RU. PLATE	2/2	"	5 THK
02	FRAME LONG & CROSS BEARER	02/12	"	ISMC 150
01	CHASSIS LONG & CROSS BEARER	02/07	"	FAB SECTION

DRAWN BY: *[Signature]*  
MANUFACTURER: **LAXMI ENGINEERING WORK**  
MITHI ROHAR GANDHIDHAM, DIST. KUTIC.

TYPE OF TRAILER: TRUCK HORSE DRAWN SEMI TRAILER OF TH AXLES, SIX WHEELER, (12 WHEELED) BANJO T SPRUNG CHASSIS, FLAT TOP PLATFORM.

SCALE	LENGTH	WIDTH	HEIGHT
1:50	7320	2600	1750
OVERALL	7475	2600	1750

THIS TYPE OF TRAILER WILL BE EQUIPPED WITH TWIN LINE PNEUMATIC BRAKE SYSTEM WITH AIR TANK, RELAY EMERGENCY VALVE & BRAKE CHAMBERS WITH PARKING BRAKE. ALL DIMENSIONS ARE IN MM.

FOR MAX. G.W.W 40200 KG. WHEN COUPLED WITH SUITABLE PRIME MOVER

..2..

**ORDER:** In view of the above, I, K.M.PATEL, Joint Director of Transport, Gujarat State, Gandhinagar, hereby approve the locally manufactured semi trailer design having **Drq.No.PB-24.T.FB.1**. Under the provisions of Rule 166 of the Gujarat Motor Vehicles Rules, 1989 and determine the maximum safe axle and gross laden weights to be assigned for the above type of semi trailer are as follows:

- |                                      |           |
|--------------------------------------|-----------|
| 1. King pin Reaction...              | 10200 kg. |
| 2. Rear Axle Weight... (Three axles) | 24000 kg. |
| 3. Gross Laden Weight...             | 34200 kg. |

**(For maximum G.V.W. 40200 kg. only when coupled with prime-mover.)**

- NOTE:**
1. This type of trailer should be coupled with prime mover (Tractor) of suitable capacity. Overall dimensions of tractor-trailer combination should be in conformity with Rule 93 of Central Motor Vehicle Rules 1989.
  2. Chassis Number should be directly punched on chassis. "T" Mark, Triangular Reflector, sides & rear safety guards should be provided and shall be affixed with reflective contour marking at the rear and side in accordance with AIS:090-2005.
  3. This type of trailer should not be registered in absence of valid "TRADE CERTIFICATE".
  4. At the time of registration or any time if the measurements & type of semi trailer does not match with approved drawing, the approval order may be cancelled.
  5. Manufacturer are informed to furnish a copy of approved drawing of the semi trailer with copy of this approval order & "Form No.21" to enable registering authority to verify measurements at the time of registration.



*(Signature)*  
28/9  
(K.M.PATEL)

Joint Director of Transport,  
Gujarat State, Gandhinagar.

No.Permit/LMT/L.E.W./463/2011/ON. 6658

Commissioner of Transport Office,

Dr.Jivraj Mehta Bhavan,

Block No.6. 2<sup>nd</sup> & 3<sup>rd</sup> Floor,

Gandhinagar. Gujarat State.

Dt: 28/9/2011

To,

M/s.LAXMI ENGINEERING WORKS. MITHI ROHAR. GANDHIDHAM. DIST: KUTCH.

Copy f.w.cs. For information to:

1. All RTO/ARTO in the State of Gujarat.
2. Section Officer, Ports & Transport Department, Block-2, 9<sup>th</sup> floor, Sachivalaya, Gandhinagar.
3. The Secretary, Ministry of Shipping, Road Transport & Highways.  
Transport Bhawan. 1 Parliament Street. New Delhi.



*(Signature)*

15-10-2011

**S. PARAMESWARAN NAIR**

ADVOCATE & NOTARY

Roll No. K 27/11067

*(Signature)*  
28/9  
(K.M.PATEL)

Joint Director of Transport,  
Gujarat State, Gandhinagar.