

No. C3/7749/TC/2009

Transport Commissionerate
Kerala, Thiruvananthapuram
Dated 25.04.2009

From The Transport Commissioner
Thiruvananthapuram.
To All Deputy Transport Commissioners,
All Regional Transport Officers,
All Joint Regional Transport Officers.
Sir,

Sub:- M.Vs.Dept - Approval for Registration of APE CITY 3 Wheeler /
Passenger Manufactured by M/s Piaggio Vehicles Pvt. Ltd. -Copy of
certificates forwarding of reg.

Ref:-1.Letter dated 07.04.2009 from M/s Piaggio Vehicles Pvt. Ltd, Pune
2.Certificate No. AAEN 0120 dtd 11.03.2009 of ARAI
3. Certificate No. AAEN 0120 E01 dtd 26.03.2009 of ARAI

M/s Piaggio Vehicles Pvt. Ltd , Pune in their letter dated 07.04.2009. has
requested to grant approval for the registration of APE CITY 3 Wheeler /
Passenger -L5M following vehicles Manufactured by Piaggio Vehicles Pvt. Ltd

The Automotive Research Association of India has granted approval to
above vehicles and certified that the vehicles comply with the CMV Rules 1989
The details of ARAI Certificate is being communicated to your office by E-MAIL...

All the Registering Authorities and Additional Registering Authorities are
directed to register the above vehicles subject to the compliance of CMV Rules,
1989 as amended up-to-date. They are also directed to verify the compliance of
provisions of Act and Rules other than those mentioned in Annexure I and
Annexure IA of the ARAI certificate. The applicant is directed to produce a copy of
the ARAI certificate before the Registering Authorities at the time of registration of
vehicles.

Yours faithfully,

Sd/-

Senior Deputy Transport Commissioner
& Secretary , STA
For Transport Commissioner

Copy to the applicant for information.
Approved for issue

Senior Superintendent
28/4/09

A A E N 0120

Date: 11th March 2009

CERTIFICATE

Cert	Brief	Drq	Total
3	5	2	10 Pgs

FOR COMPLIANCE TO THE CENTRAL MOTOR VEHICLES RULES.

1. In order to establish compliance to the provisions of CMVR, 1989, applicable as on date, documental verification/necessary testing was carried out, on the following **base model**, submitted by the vehicle manufacturer referred below:

Documental Reference			Vehicle Manufacturer	
ARAI/CMVR/499B(1365, 589)/2008-599 dt. 16.09.2008			M/s. Piaggio Vehicles Pvt. Ltd., E-2 MIDC Area, Baramati, Dist. Pune-413133. Plant: Baramati	
Diesel Engine			Engine Manufacturer	
Model	Power	cc	M/s. Greaves Cotton Ltd. Plant: LEU II, 72, SIPCOT Complex, Ranipet-632403, Tamilnadu	
GL 400 II A	5.51 kW @ 3600 rpm	395		
BASE MODEL		Type	Seating Capacity (Incl. Driver)	GVW kg
APE CITY		3 Wheeler/ Passenger-L5M	4 Persons	670

- 1a. Brief technical specifications (No. ENGG/08-09/APE CITY) of the vehicle model, as declared by the vehicle manufacturer, are enclosed with this certificate. Detailed specifications (No. ENGG/08-09/APE CITY) of the vehicle mode, are also separately issued to the vehicle manufacturer.
2. It is certified that the above **base model**, complies with the provisions of the Central Motor Vehicles Rules, 1989, as amended up-to-date, including following requirements, (as detailed at ANNEXURE-I & IA):

Mass Emission Standards	Notification	Date	Effective From	Applicable CMVR
Bharat Stage - II	GSR 720(E)	10.09.2003	01.04.2005	115 (12)
Free Acceleration Smoke	GSR 111(E)	10.02.2004	01.10.2004	115 (2) (ii)
Passby Noise Limits			01.04.2005	120 (2)
Safety Components	GSR 400(E)	31.05.2002	Notified dates	ANNEXURE-I
	S. O. 1365(E)	13.12.2004		ANNEXURE- IA
	S. O. 451(E)	30.03.2005		
Tyres / Brakes / Lamps / Reflex Reflectors	GSR 589(E)	16.09.2005	01.04.2006	95(1) / 93(4) / 104(4) / 105(1)

3. This Certificate is issued as per CMV Rule 126, to establish compliance with the Central Motor Vehicles Rules, 1989, and shall not be construed as a certificate of compliance to any rules other than those listed in ANNEXURE-I & IA. Compliance to these rules has been verified based on the use of specific components/parts/assemblies etc. details of which are given in the detailed specifications duly endorsed by ARAI as mentioned at para. 1a above. It is the vehicle manufacturer's responsibility to ensure fitment of same components/parts/assemblies etc. before submission of the vehicle for registration.
4. Further ARAI issues Type Approval Certificates for vehicles / components / parts / assemblies etc. based on the documents produced / submitted by the customer and on these basis, the vehicles are examined and if approved, the certificate is issued. ARAI is in no way responsible for any misuse of copying of any design / type / system in connection with entire vehicle / components / parts and assemblies. Breach of any statutory provision of Indian laws or laws of other countries, will be the sole responsibility of the customer and ARAI shall not be liable for any claims or damages, made by the party, whatsoever, the customer shall alone be liable for the same, and undertakes to indemnify ARAI in this regard. Further, the ARAI has the right to initiate cancellation / withdrawal of the certificate issued, in case of any fraud, misrepresentation, when it surfaces and comes in the knowledge of ARAI. The appropriate local courts at Pune shall have the jurisdiction in respect of any dispute, claim or liability arising out of this certificate / Report.

AUTHORISED SIGNATORY,

AUTHORISED SIGNATORY,



Mrs. RASHMI URDHWARESHE,
DEPUTY DIRECTOR,
APEX CELL, ARAI, PUNE.
Place of Issue : Pune

D. J. KULKARNI,
DEPUTY DIRECTOR,
DTS, ARAI, PUNE. Page 1 of 3

FOR PIAGGIO VEHICLES PRIVATE LIMITED

CERTIFIED TRUE COPY

ASHCK MEDANKAR
COMPANY SECRETARY



BRIEF TECHNICAL SPECIFICATIONS OF VEHICLE

A. Manufacturer's name and address	PIAGGIO VEHICLES PRIVATE LIMITED E-2, MIDC Area, Baramati - 413 133 Dist. Pune, India
Importer's name and address (in case of CBU)	N.A.
Country of origin, if imported	N.A.
Vehicle data	
Basic model	APE CITY
Type (Brief description)	3 Wheeler / Passenger
Category of vehicle (As per AIS: 053)	L5 M
Variants:	NA
Type / description	3 Wheeler / Passenger
Category of variant (s) (As per AIS: 053)	L5 M
Engine	
Make & country of origin, if imported	GREAVES COTTON LTD.
Model	GL 400 II A
Type	Four stroke, diesel, Forced Air cooled
Bore x stroke, mm	86 x 68
No. Of cylinders	One
Displacement	395 cc
Compression ratio	18: 1
Max. Engine output, (kW @ rpm)	5.51 @ 3600
Max. Torque, (Nm @ rpm)	16.7 @ 2200 - 2800
Air cleaner Type	Dry type
Clutch	
Type	Multi Disc, Wet type.
Gear box	
Make & Model	PIAGGIO VEHICLES PRIVATE LIMITED
Type	Constant mesh / PG1
No. Of gears	Four Forward, One Reverse
Gear ratio	Over all Ratio 19.4: 1 11.51: 1 7.04: 1 4.72: 1 N.A. N.A. 23.26: 1
Drive Axle (Front / Rear / All)	Rear
Front axle ratio	N.A.
Rear axle ratio	1.933: 1 (integral with gear box)
Steering	
Type / description	Rear
Steering wheel diameter, mm	N.A.
Ratio	1:1
Frame	
Long member size, mm	1386
Number of cross members	3

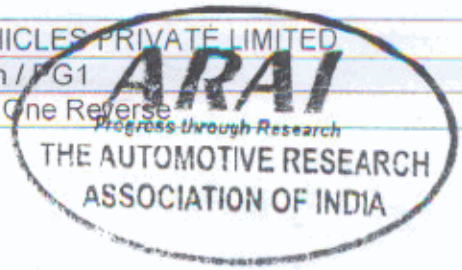
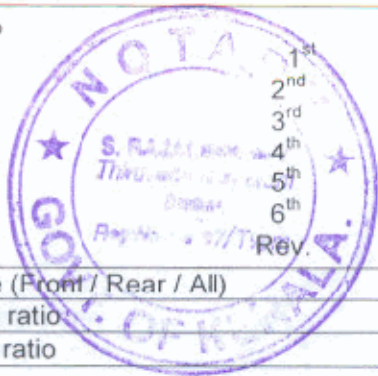

Page 24-25

Signature: Mr. S.S Sane
Designation: Sr. General Manager

Manufacturer: PIAGGIO VEHICLES PVT. LTD.	Document No: ENGG/08-09/APE CITY	Test Agency:	Cert. No
Name: Mr. S.S Sane	Sheet no.:	Signature: <i>Rashmi</i>	
Signature: <i>[Signature]</i>	Date: 02/01/2009	Name: Mrs. RASHMI URDHWARESHE	
Designation: Sr. General Manager		Designation: DEPUTY DIRECTOR	
		Date of Issue: APEX CELL, ARAI	Page 1 of 3

CERTIFIED TRUE COPY

FOR PIAGGIO VEHICLES PRIVATE LIMITED

Ashok Medankar
ASHOK MEDANKAR
COMPANY SECRETARY

Suspension	
Type / description	Front: Helical spring with dampener Rear: Swing arm type co-axial spring with shock absorber
Spring	Front: Swing arm type co-axial spring with shock absorber Rear: Helical Compression Spring
Anti-roll bar	Not provided.
Shock absorbers	Hydraulic telescopic – Front & Rear
Brake	
Service brake (Brief description)	Drum Brake hydraulically actuated Internal expanding shoe type – Combined
Auto Slack Adjuster fitted (Yes/No/Optional)	Yes
ABS fitted (Yes / No / Optional)	No
Front (Disc / Drum)	Drum
Rear (Disc / Drum)	Drum
Total braking area, cm ²	98x3
Parking brake	Mechanical, Hand operated, Actuating Rear Brakes.
Secondary brake	Any one circuit (front/rear) fail
Wheels and tyres	
Wheel rim size	3.50 – 8
Tyre size designation including ply rating / speed rating	MRF: 4.0 – 8, 4 PR, 70 E / 4.0 – 8, 6 PR, 70 E FALCON: 4.0 – 8, 6 PR, 70 E
Load index / Load rating	70
Tyre type (Radial / Cross / Tube / Tubeless)	Cross / Tube
Laden tyre pressure (front & rear), kg/cm ²	2.1 & 2.4
Electrical system	
System voltage, V	12 DC
Battery rating, Ah	50 Ah
Wiper motor	Rack type / Direct mounted
Wiping system (Brief description)	Electrically operated
Fuel Tank	
Material	Metallic
Capacity, Ltr.	10.5
Dimensions	
Wheel base, mm	1940
Overall width, mm	1400
Overall length, mm	2700
Overall height, mm	1820
Front track, mm	N.A.
Rear track, mm	1260
Min. ground clearance, mm	165
Cargo box dimensions, mm	N.A.
Load body platform area, mm	N.A.



Ref: 24-11-09
S. Rajesh K. Advocate
The Themuraitkottai
No. 12/197/V

Manufacturer: PIAGGIO VEHICLES PVT. LTD.	Document No: ENGG/08-09/APE CITY	Test Agency:	Cert. No
Name: Mr. S.S Sane	Sheet no.:	Signature: <i>[Signature]</i>	
Signature: <i>[Signature]</i>	Date: 02/01/2009	Name: Mrs. RASHMI URDHWARESHE	
Designation: Sr. General Manager		Designation: DEPUTY DIRECTOR	
		Date of Issue: APEX CELL, ARAI	Page 5 of 2

FOR PIAGGIO VEHICLES PRIVATE LIMITED

CERTIFIED TRUE COPY

[Signature]
ASHOK MEDANKAR
COMPANY SECRETARY

Weights	APE CITY
Maximum GVW, kg (for rigid vehicles)	670
Maximum GCW, kg (for articulated / combination vehicles)	N.A.
Maximum permissible FAW, kg	159
Maximum permissible RAW, kg	511
Kerb weight with 90% fuel (With spare wheel, tools, etc.), kg	370 317 <i>h</i>
Maximum grade ability in 1 st gear	20 % (11.5")
Seating	
Seating capacity	Driver + 3 Pass
Sketch showing seating layout with dimensions	Enclosed Annex- A

RajL
24.04.09

S. Rajalekshmy
Advocate & Notary
Thiruvananthapuram District
Reg : No. 82/97/Tvpm



Manufacturer: PIAGGIO VEHICLES PVT. LTD.	Document No: ENGG/08-09/APE CITY	Test Agency:	Cert. No
Name: Mr. S.S Sane	Sheet no.:	Signature: <i>[Signature]</i>	
Signature: <i>[Signature]</i>	Date: 02/01/2009	Name: Mrs. RASHMI URDHWAI	
Designation: Sr.General Manager		Designation: DEPUTY DIRECTOR	
		Date of Issue: APEX CELL, ARAI PUN	Page No

FOR PIAGGIO VEHICLES PRIVATE

CERTIFIED TRUE COPY

[Signature]
ASHOK MEDANKAR
COMPANY SECRETARY



DETAILS OF LOCATION OF CHASSIS NUMBER AND CODE FOR MONTH AND YEAR OF MANUFACTURE AS PER RULE 122 OF CMVR

Name of the Vehicle Manufacturer & Address:	PIAGGIO VEHICLES PRIVATE LIMITED E-2, MIDC Area, Baramati - 413 133 Dist: Pune, INDIA
Name of the basic model:	APE CITY
Name of Variants, if any :	NA
Place of Embossing or etching the Chassis Number (VIN Code) (Supporting details by drawing or pictures may be provided if necessary)	On Left side of the main beam, in driver cabin.

Code for month and year of production:

Code for month of production:		Code for year of production:	
Month	Code	Year	Code
January	A	2008-2009	K
February	B	2009-2010	L
March	C	2010-2011	M
April	D		
May	E		
June	F		Refer Annex - L
July	G		
August	H		
September	J		
October	K		
November	L		
December	M		

NOTE; LETTER 'I', 'O' & 'X' NOT COUNTED.

Position of the code for month of production in the Chassis number (VIN Code):	(Seventh alphabet from left)
Position of the code for year of production in the Chassis number (Vin Code):	XXXXXXXXXXXXXXXXXX (Eighth alphabet from left)
Height of the Chassis number :	6 mm

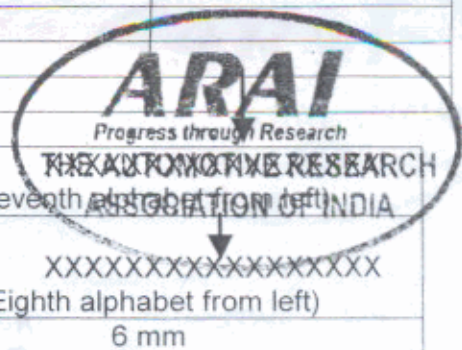

Example of Engine No.: - R7M 0474712

Example of Chassis No. (Vehicle Identification Number) with Month & Year of Manufacture: - MBX0000RFAK123456 (Refer Annex - K)

Handwritten: R/L 24.04.09

Signature: S. Rajalekshmy
Advocate & Notary
Thiruvananthapuram District
Reg : No. 82/97/Tvpm



Manufacturer: PIAGGIO VEHICLES PVT.LTD.	Document No: ENGG/08-09/APE CITY	Test Agency: Signature: <i>[Signature]</i>	Cert. No: <i>[Signature]</i>
Name: Mr. S.S Sane	Sheet no.:	Name: Mrs. RASHMI URDHWARES	
Signature: <i>[Signature]</i>	Date: 02/01/2009	Designation: DEPUTY DIRECTOR	
Designation: Sr.General Manager - Engineering		Date of Issue: APEX CELL, ARAI, PUNE	Page No 1

11 MAR 2009

ARAI/CMV No. 2009-0120

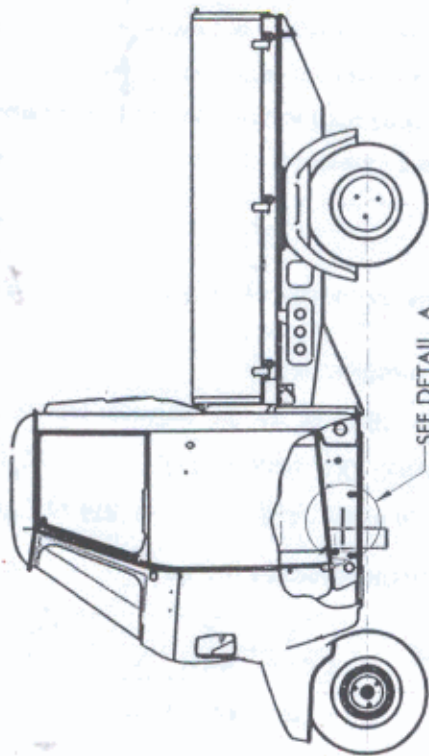

SEE DETAIL A

VIN CODE DETAILS:-

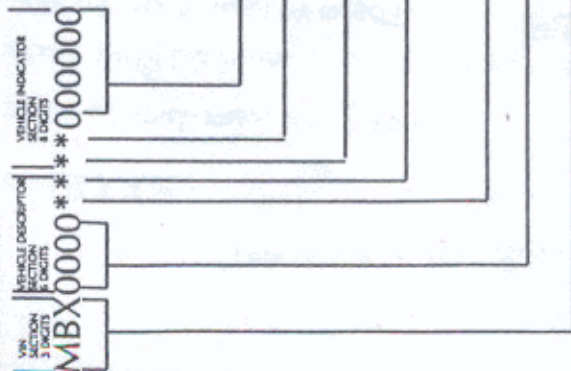

- NOTE:
1. PUNCHING SHOULD BE IN SINGLE STRAIGHT LINE
 2. NO SPACING BETWEEN NUMERALS AND ALPHABETS OF THE VIN CODE.
 3. THE VIN CODE LOCATION IS SAME FOR ALL APE 501 3 WHEELER MODELS.
 4. FONT TYPE OF VIN CODE IS ROMAN FOR LETTERS AND ARABIC FOR NUMERALS.
 5. ALL THE LETTERS AND NUMERALS OF THE VIN CODE SHOULD BE CLEARLY VISIBLE AND TRACEABLE.
 6. VIN CODE DETAILS ARE AS PER AIS 065.

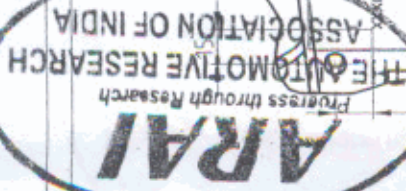

VIN CODE TO BE PUNCHED ON CENTRAL BEAM



for PIAGGIO VEHICLES PRIVATE LIMITED
 General Manager - Engineering
 S. S. JANE

Rajadekshyam
 Advocate & Notary
 Thiruvananthapuram District
 Reg: No. 82/977/vpm

① A-PICK UP WITH FIXED SIDE GATES, B-PICK UP WITH FLDG. GATES, K-PICK UP WITH FLDG. GATES (W/O CABIN DOORS), C-DELIVERY VAN, L-DELIVERY VAN (W/O DOORS), D-DAC (CARGO), F-PASSENGER, H-HI BODY, J-DAC(PASSENGER), N-DAC WITH PLATFORM, P-HI BODY W/O CABIN DOORS, Q-DAC (CARGO) W/O CABIN DOORS

② D-501-400, L-501-LPG, C-501-CNG, N-APE TRUK MARK I, F-APE XTRA LD, R-APE CITY DIESEL, S-APE CITY PETROL, T-APE CITY LPG, U-APE CITY CNG

NO	DRW	CHD	DATE	REVISION
01	AMOL	PRIVATE	26/08/08	
02			12/10/08	

ALPHABETS R, S, T, U ADDED TO 'A' FOR PROJECT CODE IN THE VIN CODE DETAILS (DETAILS SEE DDM NO. 8000709)
 ALPHABETS 'M', 'N' ADDED FOR 3 DIGITS OF VIN SECTION WITH FLDG. GATES (W/O CABIN DOORS) WAS 'C', 'K' PICK UP (DETAILS SEE DDM NO. 8000553)
 DEPUTY DIRECTOR
 APEX CELL, ARAI, PUNE

CERTIFIED TRUE COPY
 ASHOK MEDANKAR

DRW AMOL	DT. 11/06/08	APPLICABLE
CHD. SEC	DT. 12/06/08	APE THREE WHEELER ALL MODELS
CHD. KRAMARSHINDI	DT. 12/06/08	
APTD. S.S.JANE	DT. 12/06/08	

PIAGGIO VEHICLES PRIVATE LIMITED
 E-2, MIDC, BARAMATI - 413 133

SCALE: N.T.S.

REMOVE BURR AND SHARP EDGES. IF IN DOUBT ASK THIS DRAWING IS THE PROPERTY OF P.V.P. AND MUST BE RETURNED ON REQUEST. IT MUST NOT BE USED UNLESS SPECIFICALLY AUTHORIZED BY PIAGGIO VEHICLES PRIVATE LIMITED. COPIED OR LENT FOR ANY PURPOSE WITHOUT AUTHORIZATION.

DRW NO: 02
 SHEET: 1/1
 SCHEME-CHASSIS NUMBER PUNCHING: B001314

A A E N 0120 E01

Date: 26th March 2009

EXTENSION-1

Cert	Brief	Drg.	Total
2	2	—	4 Pgs

To

CERTIFICATE FOR COMPLIANCE TO THE CENTRAL MOTOR VEHICLES RULES.

1. Based on the verification of documents and tests conducted on the base model "APE CITY", with 670 kg GVW, manufactured by M/s. Piaggio Vehicles Pvt. Ltd., E-2 MIDC Area, Baramati, Dist. Pune-413133, it is declared that the compliance to the provisions of the Central Motor Vehicles Rules, 1989, as per the certificate referred in ANNEXURE-I, is also applicable to the endorsed changes in technical specifications.
2. The changes in the Technical Specifications of the base models / variants, as declared by the vehicle manufacturer, are given in ANNEXURE-I.
3. Further ARAI issues Type Approval Certificates for vehicles / components / parts / assemblies etc. based on the documents produced / submitted by the customer and on these basis, the vehicles are examined and if approved, the certificate is issued. ARAI is in no way responsible for any misuse of copying of any design / type / system in connection with entire vehicle / components / parts and assemblies. Breach of any statutory provision of Indian laws or laws of other countries, will be the sole responsibility of the customer and ARAI shall not be liable for any claims or camages, made by the party, whatsoever, the customer shall alone be liable for the same, and undertakes to indemnify ARAI in this regard. Further, the ARAI has the right to initiate cancellation / withdrawal of the certificate issued, in case of any fraud, misrepresentation, when it surfaces and comes in the knowledge of ARAI. The appropriate local courts at Pune shall have the jurisdiction in respect of any dispute, claim or liability arising out of this certificate / Report.

Rashmi

Mrs. RASHMI URDHWARESHE,
DEPUTY DIRECTOR,
APEX CELL, ARAI, PUNE.



AUTHORISED SIGNATORY,

Shrikant R. Marathe

SHRIKANT R. MARATHE,
DIRECTOR,
ARAI, PUNE. Page 1 of 2

Place of Issue : Pune.

Reference Certificate	A	A	E	N	0120	dt. 11.03.09	08-09/1208	08-09/ 1630 for E01
-----------------------	---	---	---	---	------	--------------	------------	---------------------

R.L.
24-04-09
S. Rajalekshmy
Advocate & Notary
Thiruvananthapuram District
Reg : No. 8297/Tvpm



AIS:007 Table 12 (Revision 3)

Details of change in Technical Specification

Manufacturer's name and address: **PIAGGIO VEHICLES PRIVATE LIMITED**
 E-2, MIDC Area, Baramati - 413 133
 Dist: Pune, India.

APE CITY

Name of the model and variants

CMVR Certificate No.

Date

Specification No.

AAEN 0120

11/03/2009

Valid Extension

Specifications Revision

Certification for New model

Nature of Change:

Changes in the Specifications

Sr. No.	Specifications No. and Clause No.	Description	Table - 1		Parameter (New Extension)
			Parameter (Earlier)	Parameter (New Extension)	
6.1	4.0	Weight	APE CITY	APE CITY	
6.3	4.1	Vehicle kerb weight, kg			
6.4	4.1.1	Front axle	87	87	
6.5	4.1.2	Rear axle	290	297	
6.6	4.1.3	Wheel	377	384	
6.7	4.3.3	Reference mass	527	534	
6.8	62.0	Other structural			No 2009-0120
6.9	62.1	Suspension:			
6.10	62.1.1	Front			
6.11	62.1.1.1	Type / Swing arm / telescopic/torsion bar			Swing arm

26 MAR 2009



S. Rajalekshmy
 Advocate & Notary
 Thiruvananthapuram District
 Reg: No. 82/07/Tvpm

Manufacturer: PIAGGIO VEHICLES PVT. LTD.	Document No: ENGG/APE CITY/SUSP	Test Agency:	Cert. No
Name: Mr. S.S Sane	Sheet no.:	Signature:	
Signature:	Date: 16/03/09	Name:	
Designation: Senior General Manager		Designation:	
		Date of Issue:	Page no 2

Rashmi
Mrs. RASHMI URDHWARSHI
 DEPUTY DIRECTOR
 APEX CELL, ARAI, PUNE

AIS:007 Table 12 (Revision 3)

6.12	62.1.1.2	Type of Spring (Leaf / Coil)	Coil	Coil
6.13	62.1.1.3	Type of shock absorber (hydraulic/gas/friction type)	Hydraulic	Hydraulic
6.14	62.1.2	Rear	Swing arm	Swing arm
6.15	62.1.2.1	Type (Swing arm/telescopic/torsion bar)	Coil	Rubber
6.16	62.1.2.2	Type of spring (Leaf / Coil)	Hydraulic	Hydraulic
6.17	62.1.2.3	Type of shock absorber (hydraulic/gas/friction type)		
Table - 7				
6.18		Suspension		
6.19		Type / description	Front: Helical spring with dampener Rear: Swing arm type co-axial spring with shock absorber	Front : Helical spring with dampener Rear : Rubber spring with dampener
6.20		Spring	Rear: Swing arm type co-axial spring with shock absorber Front: Helical Compression Spring	Rear : Rubber Compression Spring Front : Helical Compression Spring
6.21		Shock absorbers	Hydraulic telescopic – Front & Rear	Hydraulic telescopic – Front & Rear
6.22		Dimensions	APE CITY	APE CITY
6.23		Progressive ground clearance, mm	165	210
6.24		Weights	APE CITY	APE CITY
6.25		Maximum weight with 90% fuel (With spare wheel, tools, etc.), kg	377	384

Rajalekshmy
Advocate & Notary
Thiruvananthapuram District
Reg : No. 82/97/T/vpm

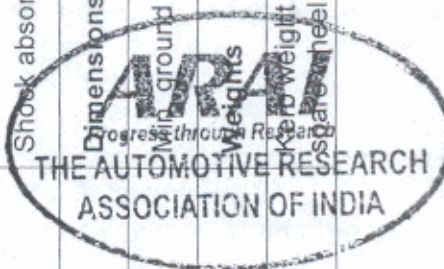

26 MAR-2009

2009-0120



Manufacturer: PIAGGIO VEHICLES PVT. LTD.	Document No: ENG/APE CITY/SUSP	Test Agency:	Cert. No
Name: Mr. S.S Sane	Sheet no.:	Signature:	
Signature:	Date: 16/03/09	Name:	
Designation: Senior General Manager		Designation:	
		Date of Issue:	Page no 2

Ramesh
Mrs. RASHMI URDHWARESHE
DEPUTY DIRECTOR
APEX CELL, ARAI, PUNE